

SMITH-COOPER[®]
INTERNATIONAL



SERIES 60



*CLASS 2500
STANDARD PORT
3-PIECE BALL VALVE*

Design & Features

Body Material

316 Stainless Steel & Carbon Steel

3-Piece Design

In-line serviceable swing-out center section allows easy access to internal valve components without disturbing alignment of pipe.

Stem Design

Live-loaded, bottom entry, blowout proof, anti-static stem featuring packing that extends valve cycle life over conventional ball valves and is best choice for actuation.

Stem seals are live-loaded using Belleville springs to provide consistent sealing forces, reducing or eliminating the need for frequent seal adjustment. High-strength 17-4PH stainless steel as standard material.

Tongue and Groove Design

Fully encapsulated body seals, allowing ends to be welded in-line, without time consuming and labor intensive disassembly.

Design compensates for bolt expansion and reduces the chance of external leakage.

Helps prevent seal ruptures in high pressure, cryogenic or steam applications.

Floating Ball Design

Precision engineered and machined solid stainless steel ball with relief hole in the stem slot prevents build-up of cavity pressure while the valve is open.

Slotted Seat Design

Relief slots help equalize body pressure and assure leak-tight sealing. Seats also provide a wiping action that cleans ball and seats each time valve is cycled.

Choice of Seats and Seals

A choice of seat material is available for the most demanding applications.

Integral Mounting Pad

Permits easy field conversion from manual operation to power actuation.

Lockable Handle

All Sharpe® Series 60 valves are supplied with lever or pipe handles and are designed to permit locking the valve in either the open or closed position.

Traceability

Body and end piece castings are marked with heat codes providing traceability to the chemical analysis and material test reports performed at the foundry. CMTR's (Certified Material Test Reports) are available upon request.

Parts & Materials

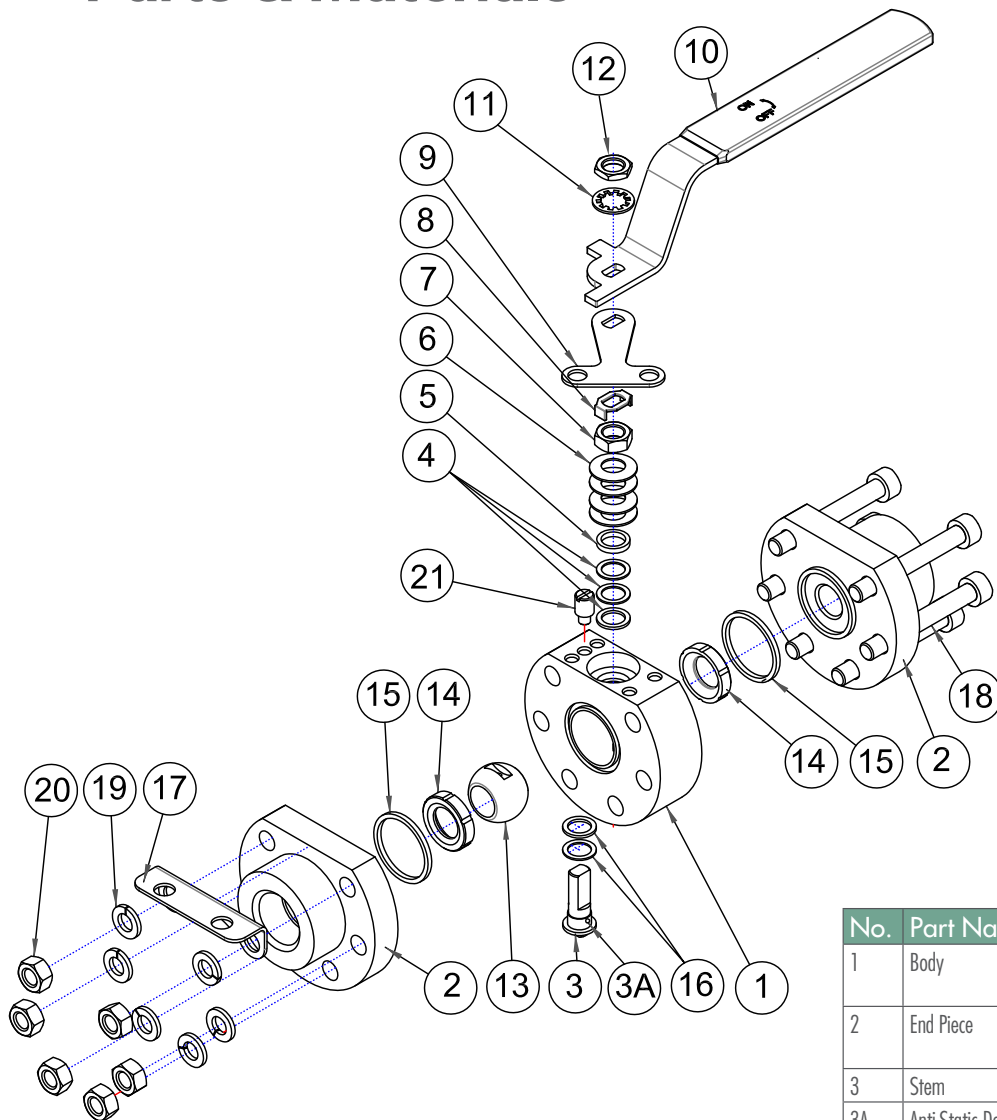

No.	Part Name	Qty	Material
1	Body	1	316 Stainless Steel ASTM A351 CF8M Carbon Steel ASTM A216 WCB
2	End Piece	2	316 Stainless Steel ASTM A351 CF8M Carbon Steel ASTM A216 WCB
3	Stem	1	17-4PH Stainless Steel
3A	Anti-Static Device	1	316 Stainless Steel
4	Stem Packing	3/1	Nova / Graphite
5	Gland	1	300 Series Stainless Steel
6	Belleville Washer	4	300 Series Stainless Steel
7	Packing Nut	1	300 Series Stainless Steel
8	Lock Tab	1	300 Series Stainless Steel
9	Upper Locking Device	1	300 Series Stainless Steel
10	Handle	1	300 Series Stainless Steel
11	Lock Washer	1	300 Series Stainless Steel
12	Handle Nut	1	300 Series Stainless Steel
13	Ball	1	316 Stainless Steel
14	Seat	2	Delrin®, Peek
15	Body Seal	2	Graphite, Viton®, PTFE
16	Thrust Bearings	2	Nova / PEEK
17	Lower Locking Device	1	300 Series Stainless Steel
18	Body Bolts	6/8*	ASTM A193 Gr B8/A2-70 Stainless Steel Class 2
19	Body Washers	6/8*	304 Stainless Steel
20	Body Nuts	6/8*	300 Series Stainless Steel
21	Stop Pin	1	300 Series Stainless Steel

*1-1/2" & 2" Sizes

Dimensions

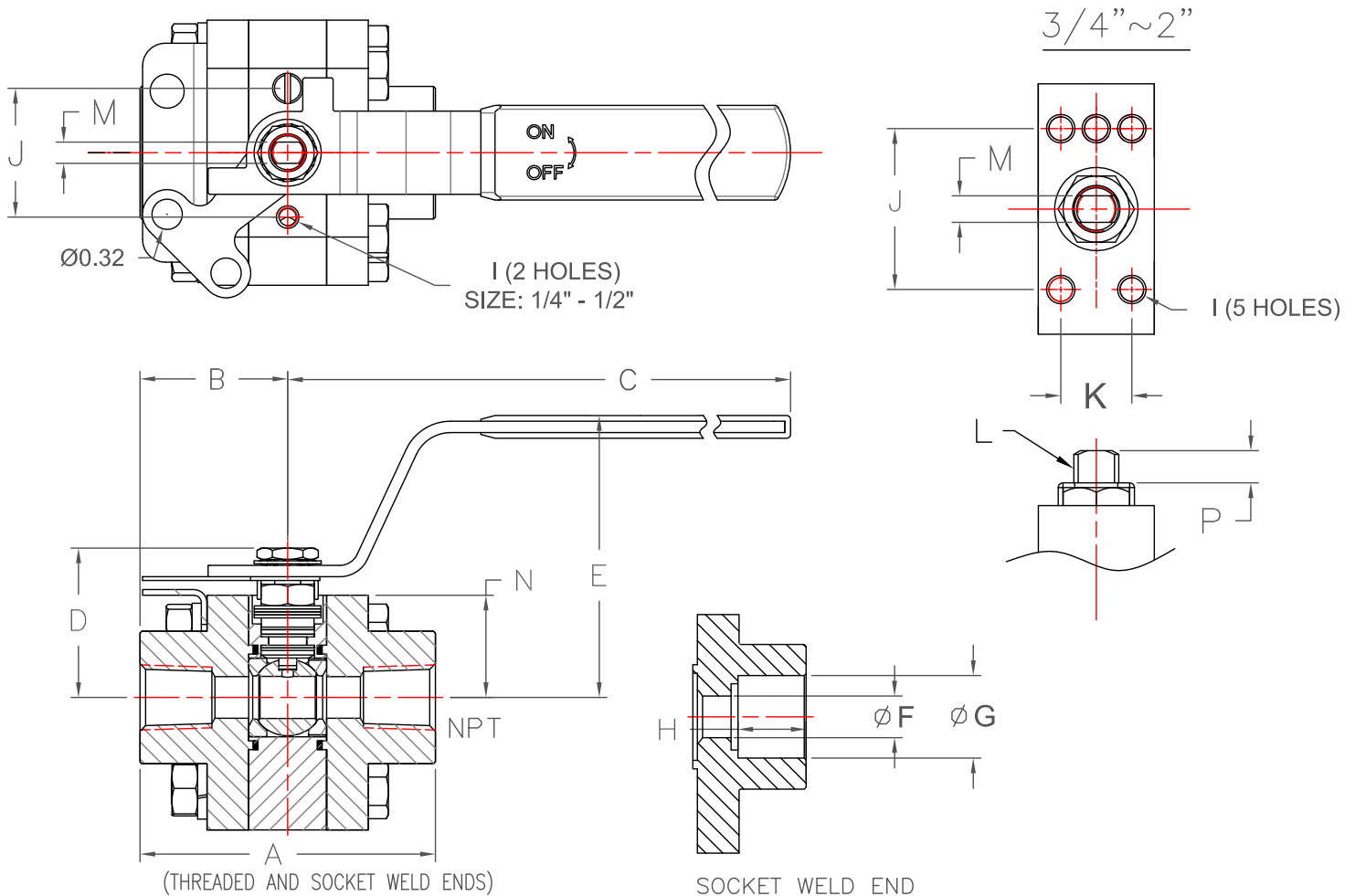

Dimensions (Inches)

Size	A	B	C	D	E	F	G	H	I	J	K	L	M	N	P
1/4	3.00	1.50	7.11	1.55	2.93	0.43	0.56	0.75	M5x.8	1.34	-	3/8-24 UNF	0.220	1.06	0.37
3/8	3.09	1.54	7.11	1.55	2.93	0.43	0.69	0.75	M5x.8	1.34	-	3/8-24 UNF	0.220	1.06	0.37
1/2	3.09	1.54	7.11	1.55	2.93	0.43	0.86	0.71	M5x.8	1.34	-	3/8-24 UNF	0.220	1.06	0.37
3/4	3.49	1.74	7.11	1.68	3.06	0.56	1.07	0.63	M5x.8	1.34	0.59	3/8-24 UNF	0.220	1.18	0.38
1	4.00	2.00	7.70	2.16	2.48	0.81	1.33	0.98	M5x.8	1.65	0.94	7/16-20 UNF	0.295	1.50	0.57
1-1/2	5.07	2.54	11.53	2.89	3.15	1.25	1.91	0.94	M6x1.0	1.57	1.42	9/16-18 UNF	0.342	1.97	0.53
2	6.14	3.07	11.53	3.08	3.29	1.50	2.41	1.06	M6x1.0	1.97	1.57	9/16-18 UNF	0.342	2.17	0.54

The dimensions above are for informational purpose only. Please refer to Sharpe® Valves if you need dimensions for construction.

Pressure-Temperature Ratings Series 60

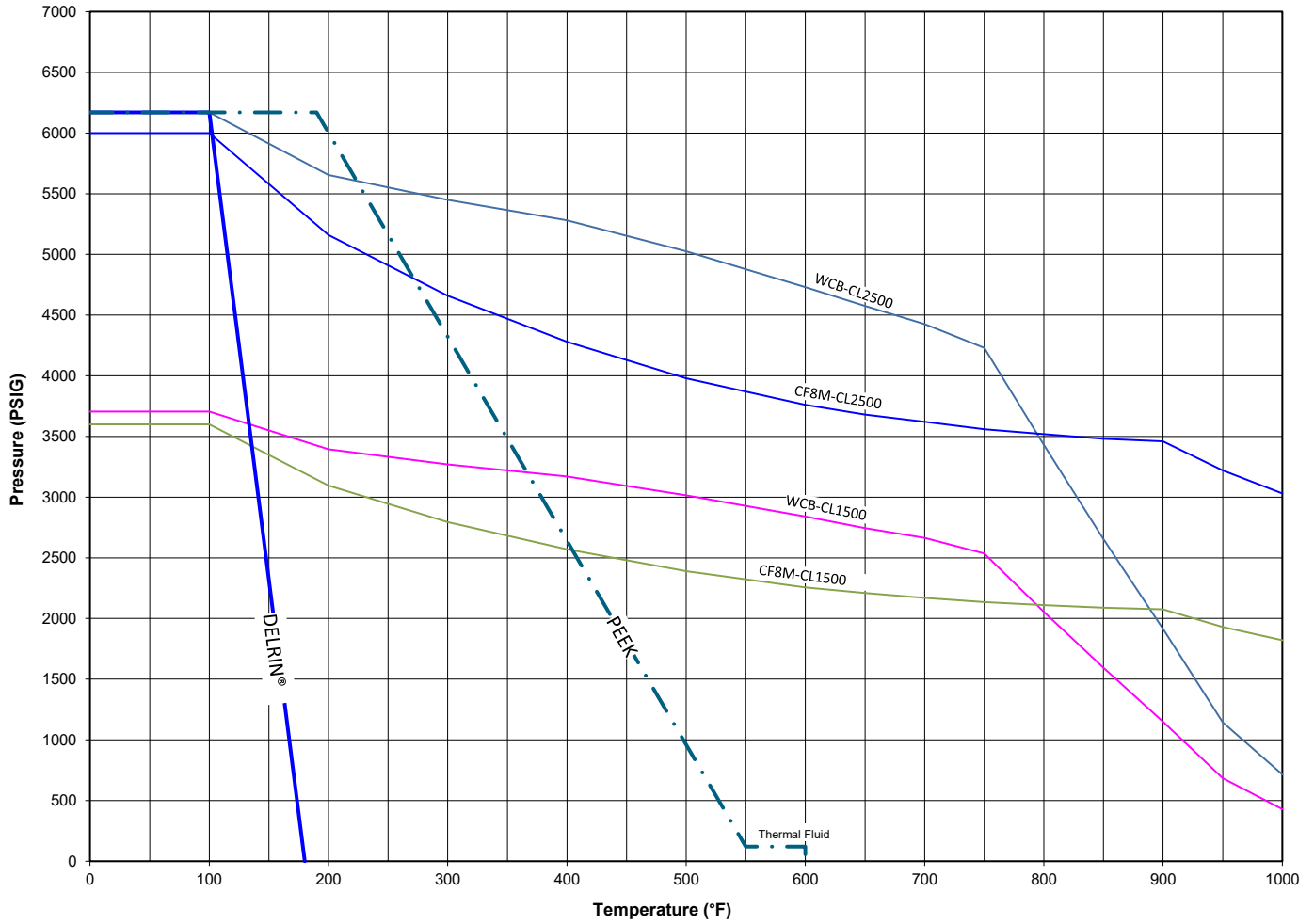

Size	Cv	Approx. Weight Lbs.
1/4	5	3.55
3/8	8	3.55
1/2	23	3.50
3/4	61	5.30
1	73	9.90
1-1/2	82	21.00
2	150	29.00

How to Order

Fig: 1 - 1/2 - 60 - 4 - 6 - D - T - TE

Size	Series	Body & Ends	Trim	Seat	Seal	Ends
1/4	60	4 Carbon Steel	6 17-4PH Stainless Steel	D Delrin®	G Graphite	TE Threaded
3/8		6 Stainless Steel	Stem and 316 Stainless Steel Ball	P Peek	V Viton®	SW Socket Weld
1/2						BW Butt-weld (Sch 160)*
3/4						1 ANSI CL1500 RF Flange*
1						1J ANSI CL 1500 RTJ Flange*
1-1/2						2 ANSI CL2500 RF Flange*
2						2J ANSI CL2500 RTJ Flange*

*POA

Viton® is a registered trademark of E.I. Dupont. | Delrin® is a registered trademark of E.I. Dupont.

