



Valves, Automation & Controls

Series 30276  
GATE VALVE

### Design Features

- 200 CWP
- 316 stainless steel
- Threaded in bonnet
- Threaded or socket weld ends
- Solid wedge disc
- Non-rising stem
- Hydrostatic shell test at 300 psi



USA 800-766-0076

Fax 323-890-4456

[www.smithcooper.com](http://www.smithcooper.com)

[www.sharpevalves.com](http://www.sharpevalves.com)

Los Angeles, CA

Chicago, IL

Atlanta, GA

Vancouver, WA

Houston, TX

## Dimensions, Parts & Materials

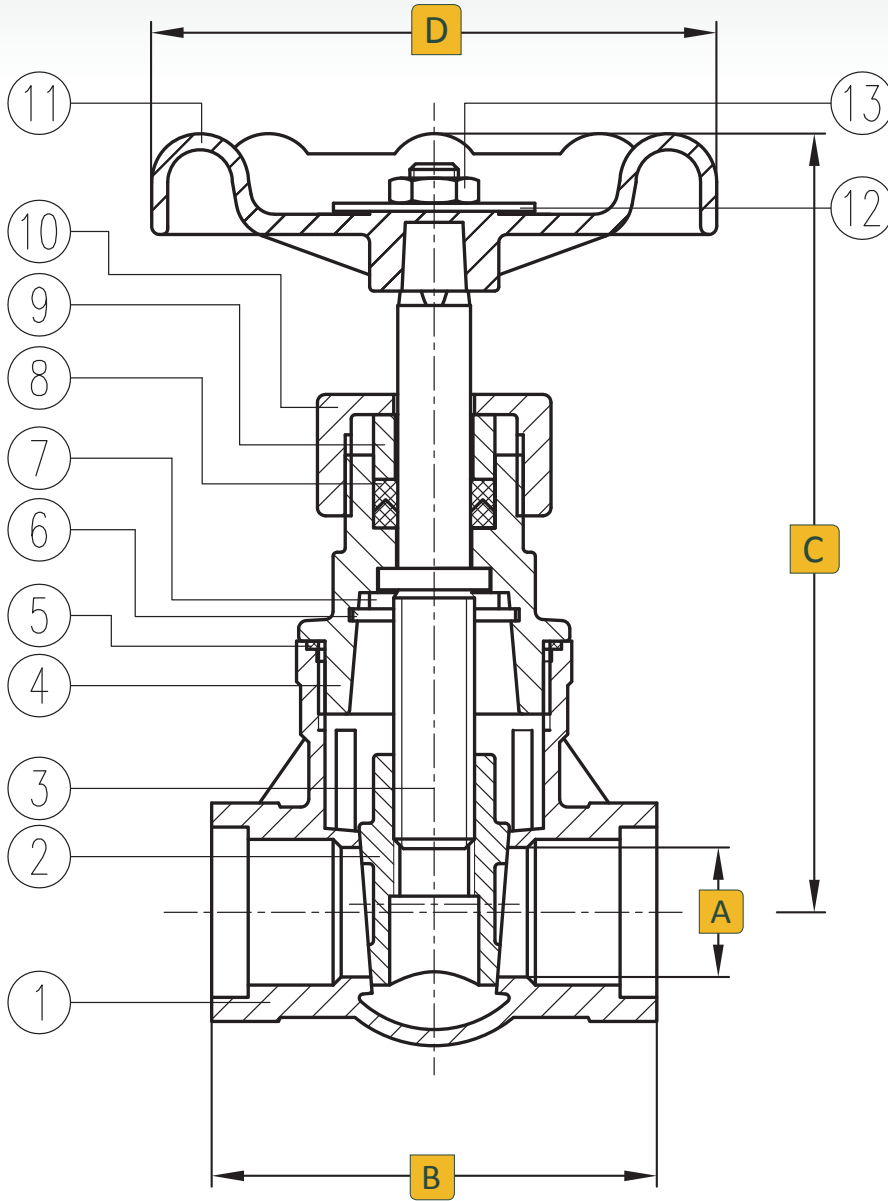

No.	Part Name	Qty	Material
1	Body	1	316 Stainless Steel
2	Disc	1	316 Stainless Steel
3	Stem	1	316 Stainless Steel
4	Cap	1	316 Stainless Steel
5	Seal	1	PTFE
6	Washer	1	316 Stainless Steel
7	Thick Washer	1	316 Stainless Steel
8	Packing	1	PTFE
9	Bush	1	304 Stainless Steel
10	Gland Nut	1	304 Stainless Steel
11	Handle Wheel	1	Aluminum
12	Name Plate	1	Aluminum
13	Nut	1	304 Stainless Steel

Dimensions (Inches)

Size	A	B	C	D
1/2	0.59	2.16	4.76	2.76
3/4	0.79	2.36	5.04	2.76
1	0.98	2.68	5.43	3.15
1-1/4	1.26	2.99	6.10	3.15
1-1/2	1.56	3.15	7.36	3.94
2	1.97	3.66	8.50	3.94
2-1/2	2.56	4.60	10.35	4.53
3	3.15	5.12	11.61	4.53

## Technical Information

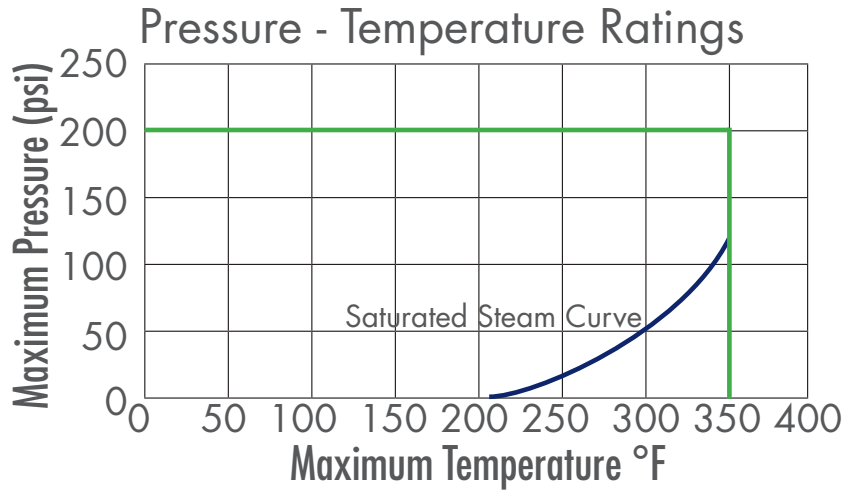

## How to Order

Size	Series	Ends	
1/4	30276	TE	Threaded
3/8		SW	Socket Weld
1/2			
3/4			
1			
1-1/4			
1-1/2			
2			
2-1/2			
3			

Example: 1 - 30276 - TE = 1-30276-TE