



Valves, Automation & Controls

Series 40276
 GLOBE VALVE

Design Features

- 200 CWP
- 316 stainless steel
- Threaded-in bonnet
- Threaded or socket weld ends
- Rising stem
- Hydrostatic shell test at 300 psi



Dimensions, Parts & Materials

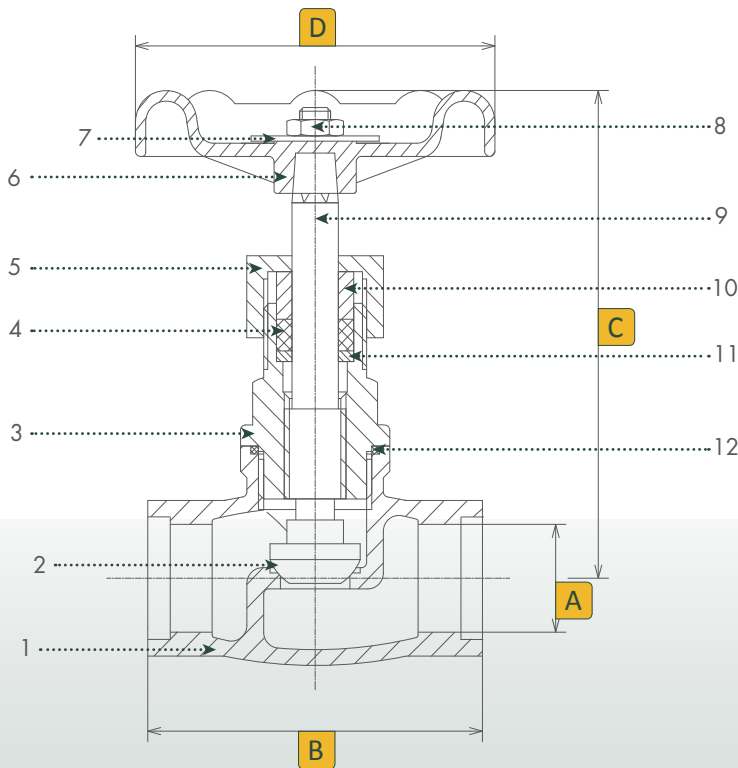

No.	Part Name	Qty	Material
1	Body	1	316 Stainless Steel
2	Core	1	316 Stainless Steel
3	Bonnet	1	316 Stainless Steel
4	Packing	1	PTFE
5	Gland Nut	1	304 Stainless Steel
6	Hand Wheel	1	Aluminum
7	Name Plate	1	Aluminum
8	Nut	1	304 Stainless Steel
9	Stem	1	316 Stainless Steel
10	Gland	1	304 Stainless Steel
11	Washer	1	316 Stainless Steel
12	Seal	1	PTFE

Dimensions (Inches)

Size	A	B	C	D
1/2	0.66	2.64	3.55	2.73
3/4	0.86	2.93	3.67	2.73
1	1.13	3.61	4.10	3.12
1-1/4	1.44	4.13	4.49	3.12
1-1/2	1.68	4.68	5.34	3.90
2	2.15	5.50	5.77	3.90

USA 800-766-0076

Fax 323-890-4456

www.smithcooper.com

www.sharpevalves.com

Los Angeles, CA

Chicago, IL

Atlanta, GA

Vancouver, WA

Houston, TX



Valves, Automation & Controls

Series 40276 GLOBE VALVE

Technical Information

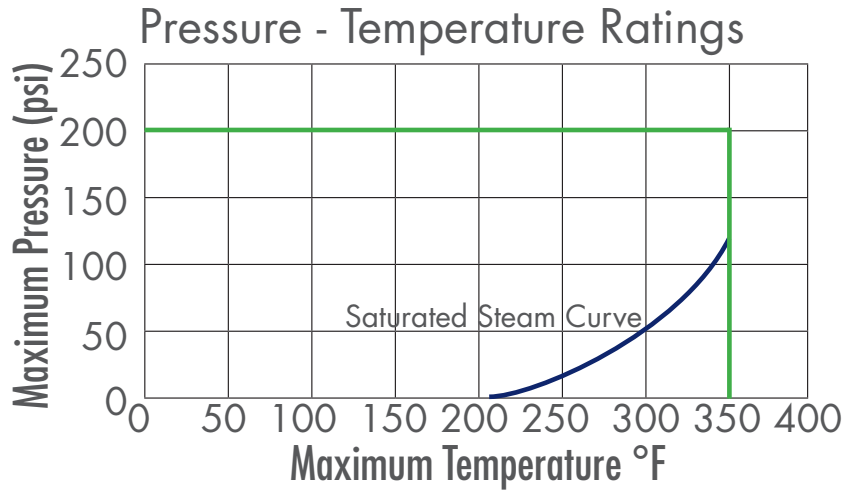

How to Order

Size	Series	Ends	
1/2	40276	TE	Threaded
3/4		SW	Socket Weld
1			
1-1/4			
1-1/2			
2			

Example: 1 - 40276 - TE = 1-40276-TE