

Class 250 • Bolted Cap • Bronze Trim • Flanged Ends

F-947 Check Valve

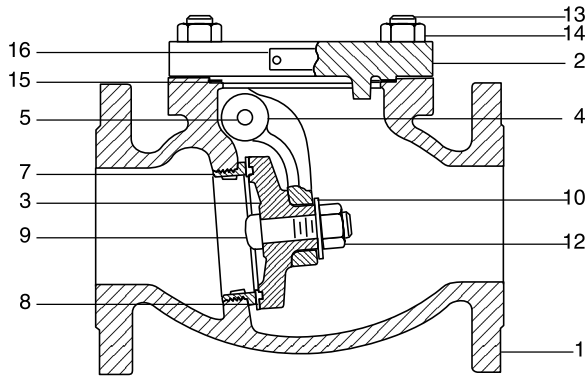

Materials of Construction

No.	Description	Material	ASTM
1	Body	Cast Iron	A126 Class B
2	Cap	Cast Iron	A126 Class B
3	Disc	Bronze (2" - 3")	B584 C84400
		Cast Iron (4" - 8")	A126 Class B
4	Hinge	Ductile Iron	A536 Gr. 65-45-12
5	Hinge Pin	13 Cr. Stainless Steel (2" - 3")	A276 Type 410
		Bronze (4" - 8")	
6	Hinge Pin Plug*	Bronze	B16 C36000
7	Body Seat Ring	Bronze	B584 C84400
8	Disc Seat Ring	Bronze (4" - 8")	B584 C84400
9	Disc Bolt	Steel (4" - 8")	
10	Disc Nut Washer	Steel	
12	Disc Bolt Nut	Steel - Dichromate Fin.	
13	Cap Studs	Steel	A108
14	Cap Stud Nuts	Steel	A563 Gr. A
15	Gasket	Aramid Fibers with SBR Binder	
16	Identification Plate	Aluminum	

* Not shown

See page 5 for Pressure Temperature Ratings

Industry Standards

Military Specification: MIL-V-18436 Group B, Type 3, Trim 5
MSS SP-71, Type 1

Dimensions and Weights

Inches (millimeters) - Pounds (kilograms)

Valve Size	Dimensions		WT
	B	M	
2	5.25	10.50	46
	(133)	(267)	(21)
2 ½	6.00	11.50	64
	(152)	(292)	(29)
3	6.25	12.50	90
	(159)	(318)	(41)
4	7.25	14.00	133
	(184)	(356)	(60)
6	9.00	17.50	250
	(229)	(445)	(113)
8	11.00	21.00	410
	(279)	(533)	(185)

