

# Class 150 • Union Bonnet • PTFE Disc • Threaded Ends

## Globe Valve Figure B-22T

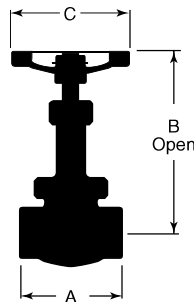
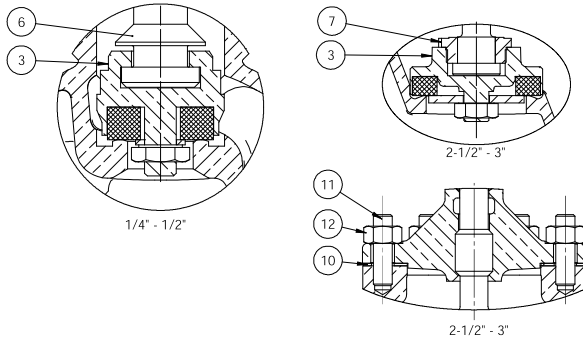
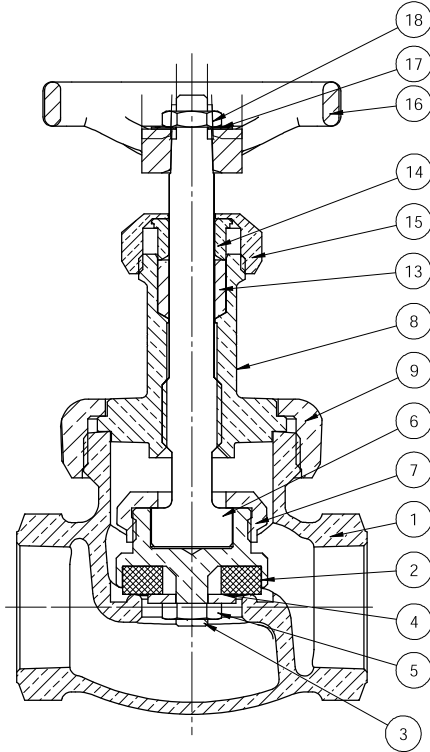

**Industry Standards**  
Complies with MSS SP-80 Type 2  
See Page 6 for Pressure-Temperature Ratings

## Materials of Construction

No.	Description	Material	ASTM Spec.
1	Body	Bronze	B-62 C83600
2	Disc	PTFE (15% Glass Filled)	
3	Disc Holder	(1/4" - 1/2") Brass	B-16 H02
		(3/4" - 3") Bronze	B-62 C83600
4	Disc Washer	Brass	B-16 H02
5	Lock Nut	Brass	B-16 H02
6	Stem	(1/4" - 3/8") Bronze	B-371 C69400
		(1/2" - 3") Bronze	B-371 C69400
7	Disc Stem Ring	(1/2" - 3/4") Brass	B-16 H02
		(2 1/2" - 3") Bronze	B-61 C92200
8	Bonnet	(1/4" - 3/8") Brass	B-16 H02
		(1/2" - 3") Bronze	B-62 C83600
9	Union Bonnet Ring	(1/4" - 2") Bronze	B-62 C83600
10	Gasket	Synthetic Glass Fiber with Nitrile Binder	
11	Stud	Steel Cadmium	A-109 C1145
12	Nut	Mild Steel	A-563 GR. A
13	Packing	Graphite (Asbestos Free)	
14	Gland	Brass	B-16 H02
15	Packing Nut	(1/4" - 1 1/2") Brass	B-16 H02
		(2" - 3") Bronze	B-61 C92200
16	Handwheel	Cast Iron	
17	ID Plate	Aluminum	
18	Lock Nut	Steel Cadmium	

**NOTE:**

The addition of the letter "K" at the end of the figure number designates valves assembled & tested in the USA. Materials of Construction & Dimensions are the same.

## Dimensions and Weights Inches (millimeters) - Pounds (kilograms)

Valve Size	Dimensions			Wt.
	B	C	A	
1/4	4.19	2.76	1.94	0.97
	(107)	(70)	(49)	(0.44)
3/8	4.20	2.76	1.94	0.99
	(107)	(70)	(49)	(0.45)
1/2	4.06	2.76	2.56	1.25
	(103)	(70)	(65)	(0.57)
3/4	5.00	2.76	2.96	1.91
	(127)	(70)	(75)	(0.87)
1	5.59	4.02	3.50	3.21
	(142)	(102)	(89)	(1.46)
1 1/4	6.51	4.02	4.02	4.47
	(165)	(102)	(102)	(2.03)
1 1/2	6.91	4.02	4.58	6.25
	(176)	(102)	(116)	(2.84)
2	7.40	4.76	5.70	11.07
	(188)	(121)	(145)	(5.03)
*2 1/2	8.69	5.51	7.25	19.65
	(221)	(140)	(184)	(8.93)
*3	10.25	5.98	8.50	33.22
	(260)	(152)	(216)	(15.10)

\*2 1/2" and 3" have Bolted Bonnet