



Three Piece High Performance Fire Safe Valves

Tri-Pro Series Models / Full Port

HPF50 - (316SS)
HPF40 - (WCB)

Size Range:
1/4" - 4"

Pressure Rating:
NPT/SW/BW
3000 MAWP/WOG 1/4" - 3/4"
2250 MAWP/WOG 1" - 4"
Flanged End - Class 600

Temp. Rating:
See Chart 1 & 2 on pages 4 and 5.

Models / Reduced

HPS50 - (316SS)
HPS40 - (WCB)

Size Range:
1/2" - 4"

Pressure Rating:
3000 MAWP/WOG 1/2" - 1"
2250 MAWP/WOG 1-1/4" - 4"
Temp. Rating:
Consult Factory

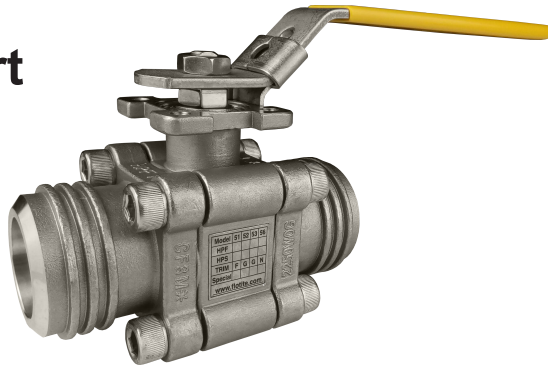

1" HPF52 (SW)
weld in place



1 1/2" Tri-Pro
HPF with
Cryogenic Stem
Extension



Tri-Pro Series	
STANDARD PRODUCT NUMBER	
HPF51-SS-1-FGFG-L	(Full-Port SS NPT)
HPF52-SS-2-FGFG-L	(Full-Port SS SW)
HPF53-SS-3-FGFG-L	(Full-Port SS BW)
HPF56-SS-6-FGFG-L	(Full-Port SS FLANGED)
HPF41-CS-1-FGFG-L	(Full-Port CS NPT)
HPF42-CS-2-FGFG-L	(Full-Port CS SW)
HPF43-CS-3-FGFG-L	(Full-Port CS BW)
HPF46-CS-6-FGFG-L	(Full-Port CS FLANGE)
HPS51-SS-1-FGFG-L	(Reduced-Port SS NPT)
HPS52-SS-2-FGFG-L	(Reduced-Port SS SW)
HPS53-SS-3-FGFG-L	(Reduced-Port SS BW)
HPS41-CS-1-FGFG-L	(Reduced-Port CS NPT)
HPS42-CS-2-FGFG-L	(Reduced-Port CS SW)
HPS43-CS-3-FGFG-L	(Reduced-Port CS BW)



3" HPF51 (NPT)

Design Features / Options

Tri Pro's Advantage

- | | |
|--|--|
| • Fire Safe Certified to API 607 7th Edition | • Ability to handle extreme pressure and temperature shock |
| • ISO 5211 Actuator Mounting Pad | • Ability to withstand higher pressure drop |
| • Secondary media containment(available) | • Ability to handle slurries and resist abrasion and wear |
| • Anti-static grounding device | • Bubble tight sealing to 500°F |
| • Weld-in-Place, SW / BW | • Bubble tight sealing to 2250 psi / 3000 psi |
| • Protected seat design | • Ability to handle thermal fluids and super heated steam |
| • Two fully contained body seals | • Superior stem seal design |
| • Cap screw body assembly | |
| • Cryogenic service (available) | |
| • V-Port control (available) | |
| • Metal seats (available) | |

REFINED BY DESIGN, DIFFERENT BY INTENT

Tri-Pro! One Valve for Most Applications

Design Specifications and Standards of Compliance

Technical Specification

ANSI Class 600/800

I-SO Mount Actuator Mounting, 4 Bolt design eliminates torsional stress, actuator can be removed while valve is under full pressure

Parallel flat stem head for positive ball position indication. 17-4 PH as standard stem material

Anti-static grounding devices at two locations provide electrical continuity

Pocketed and recessed seats with secondary metal backup seal

Fully encapsulated graphite gaskets isolate media from atmosphere

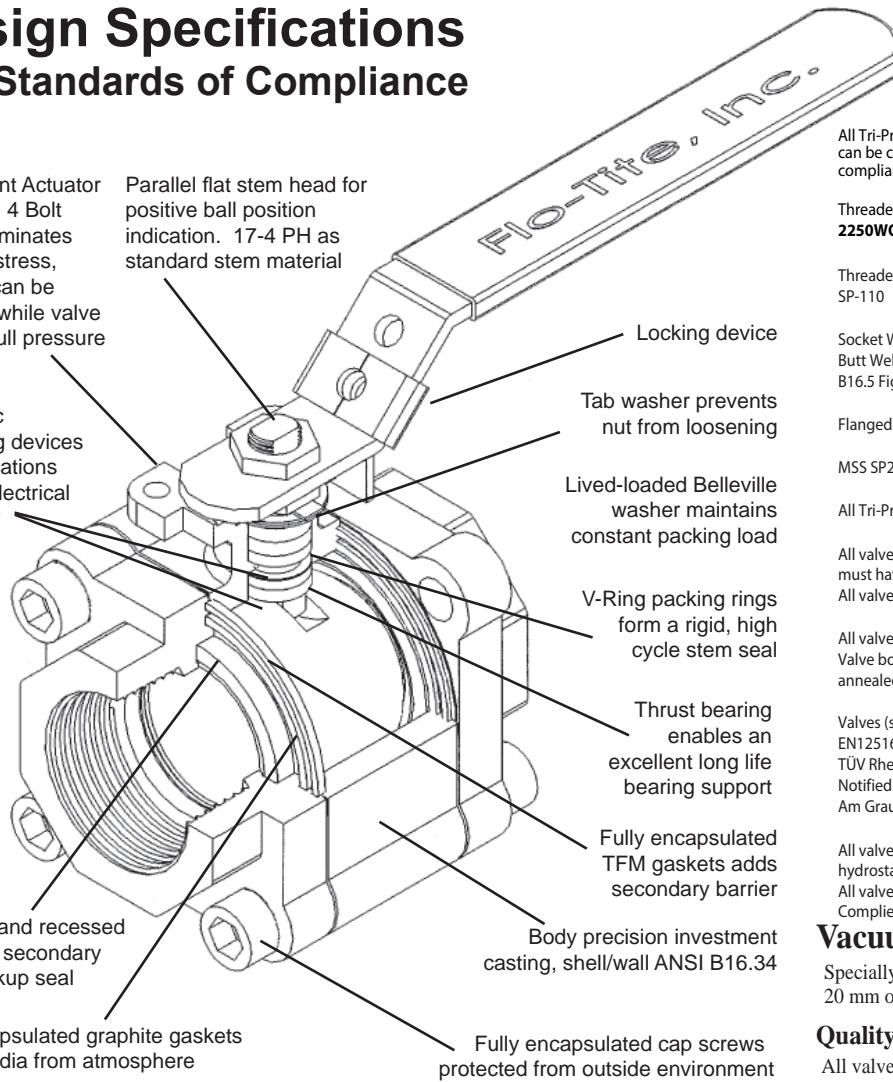

Locking device

Tab washer prevents nut from loosening

Lived-loaded Belleville washer maintains constant packing load

V-Ring packing rings form a rigid, high cycle stem seal

Thrust bearing enables an excellent long life bearing support

Fully encapsulated TFM gaskets adds secondary barrier

Body precision investment casting, shell/wall ANSI B16.34

Fully encapsulated cap screws protected from outside environment

All Tri-Pro valves are designed to meet ASME/ANSI B16.34 Class 600 specifications and can be certified as such upon request at order submittal. The valve design is in compliance with BS 5351, BS 5159.

Threaded and Socket Welding Ends meet **ASME/ANSI B16.34 Class 600/800 or 2250WOG (sizes: 1"~4")/3000WOG (size: 1/4"~3/4")**.

Threaded End Connections meet ASME/ANSI B1.20.NPT, BSPT ISO R/7, BS21, MSS-SP-110

Socket Weld End Connections meet ASME/ANSI B16.11, MSS-SP-110
Butt Weld End Connections meet MSS SP72, ANSI B16.25, B16.5 Figure 2 detail recommended sch.40 up to 1000 psi, sch.80 up to 2200 psi.

Flanged End Connections meet ASME/ANSI Class 600, ASME/ANSI B16.10 and B16.5.

MSS SP25 compliance for standard marking system.

All Tri-Pro Valves with 316SS stem meet NACE MR0175 for sour gas service.

All valves are Fire Safe & certified to API 607 7th Edition. Fire Safe Designed Valves must have graphite stem packing.

All valves are in compliance with federal Spec WW-V-35C Type II.

All valves are in compliance with API 608.

Valve body and end connections are high quality investment cast and solution annealed/normalized.

Valves (sizes: 1-1/4" ~ 2") certified to European Standards: EN 1226-1, EN 10213, EN12516-2 by:

TÜV Rheinland Industrie Service GmbH

Notified Body, ID-No. 0035

Am Grauen Stein, D-51105 Köln

All valves have CE marking on either metal name plate or handle sleeve. All valves are hydrostatically shell tested to 1.5 x rating.

All valves 100% air tested under water at 80-100 psi.

Complies with API-598, BS 6755 Pt.2.

Vacuum Service Suitable to 25 Torr

Specially cleaned and lubricated valves can handle services 20 mm of Hg (20 micron)

Quality Assurance

All valves are manufactured to ISO 9001 quality standards.

HPS	HPF	Bolt Size	Bolt Torque in-lbs
3/4"	1/4"-1/2"	M8	200
1"	3/4"	M8	240
1 1/4"	1"	M10	330
1 1/2"	1 1/4"	M10	417
2"	1 1/2"	M12	521
2 1/2"	2"	M14	521
3"	2 1/2"	M16	1440
4"	3"	5/8"	950
	4"	3/4"	

1/4" - 2"

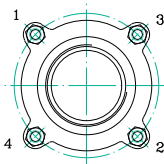

2 1/2" FP
3" RP

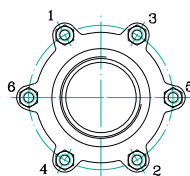

3"

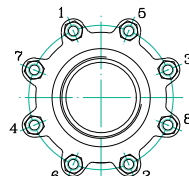

4"

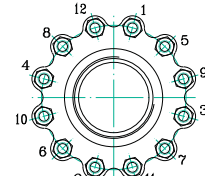

Seat Code	Seat Material
F	Super-Tek (TFM)
Y	Super-Tek III (carbon graphite filled TFM)
S	S-Tek 50% Stainless filled PTFE
U	UHMWPE
P	PEEK
M	Metal

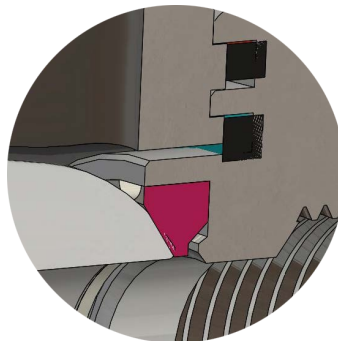
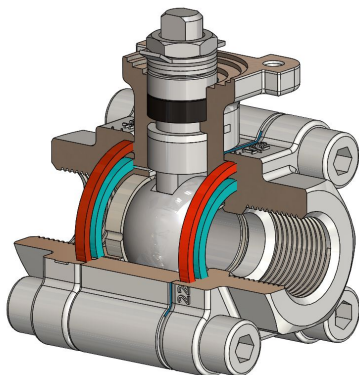

Detail of protected seat and encapsulated body seal design isolates and protects both seats and seals from flow path. Helps prevent cold flow.



Seats & dual body seals assemble into valve end caps

BILL OF MATERIALS:

ITEM	NAME	STAINLESS STEEL	CARBON STEEL	QTY
1	BODY	ASTM A351 CF8M	ASTM A216 WCB	1
2	CAPS	ASTM A351 CF8M	ASTM A216 WCB	2
3	BALL	ASTM A351 CF8M	ASTM A351 CF8	1
4	SEATS	# TFM	TFM	2
5	GASKETS	# TFM	TFM	2
6	GASKETS	# Graphite	Graphite	2
7	BOLT **	EN3506 A2-70/ ASTM A193 B8	EN3506 A2-70/ ASTM A193 B7	8
8	STEM	17-4PH	17-4PH	1
9	THRUST BEARING	# CPTFE	CPTFE	1
10	THRUST WASHER	# 50%SS PTFE	50%SS PTFE	1
11	STEM PACKING	# Graphite	Graphite	SET
12	PACKING FOLLOWER	SS304	SS304	1
13	BELLEVILLE WASHERS	SS304	SS304	2
14	LOCK WASHER	SS304	SS304	1
15	STEM NUTS	SS304	SS304	2
16	HANDLE	SS304	SS304	1
17	STOPPER	SS304	SS304	1
18	PLASTIC COVER	Plastic	Plastic	1
19	LOCKING DEVICE	SS304	SS304	1
20	ANTI-STATIC SPRINGS	SS301	SS301	2
21	ANTI-STATIC BALLS	SS316	SS316	2

Parts included in the repair kits

* All SS welded ends 316L

** 316SS bolting available, C/F

**1/4"-2"
Tri-Pro
Exploded
View**

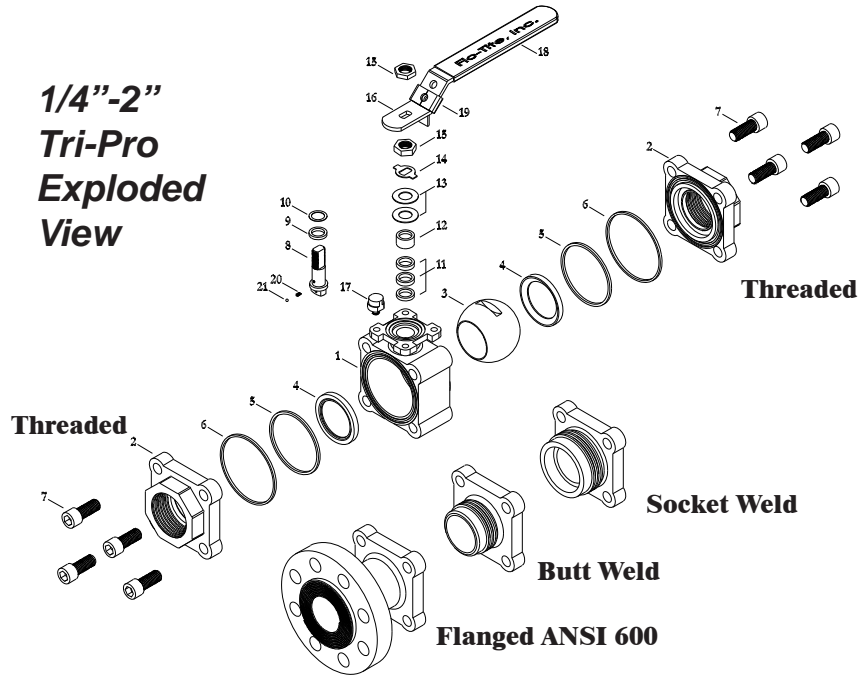

Ball Design Added Safety Feature

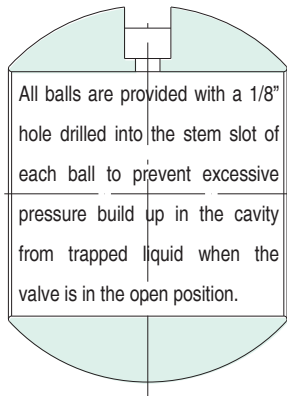

All balls are provided with a 1/8" hole drilled into the stem slot of each ball to prevent excessive pressure build up in the cavity from trapped liquid when the valve is in the open position.

Flo-Tite's Van Guard Stem Sealing System

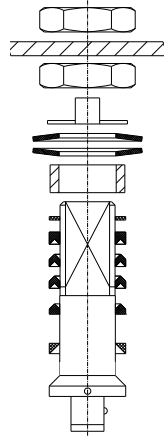

Flo-Tite's Van Guard Seal, state of the art stem sealing system. Incorporating a triple set of valve stem seals, this unique system eliminates the possibility of valve stem leaks in most all media applications. Improved thrust washer design allows more sealing surface effectively blocking all leak paths during rotation.

V-Ring Packing Set expands sideways as it is compressed and pressurized blocking all air pockets. The Van-Guard stem system is energized by Belleville washers which continuously adjusts packing compression to compensate for wear, pressure, or temperature fluctuations.

Note: • Standard Valve is Fire Safe Design with Graphite Packing.

• For higher sealing requirements, optional O-ring is available upon request.

**2-1/2"-4"
Tri-Pro
Exploded
View**

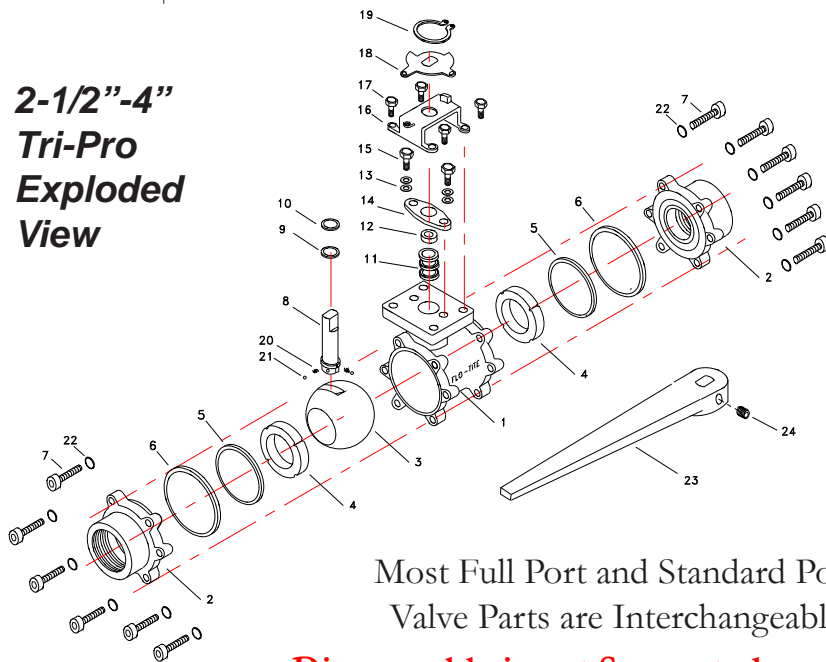

Most Full Port and Standard Port Valve Parts are Interchangeable

**Disassembly is not Suggested.
Disassembly will VOID the valve warranty.**

BILL OF MATERIALS:

ITEM	NAME	STAINLESS STEEL	CARBON STEEL	QTY
1	BODY	ASTM A351 CF8M	ASTM A216 WCB	1
2	CAPS	ASTM A351 CF8M	ASTM A216 WCB	2
3	BALL	ASTM A351 CF8M	ASTM A351 CF8	1
4	SEATS	# TFM	TFM	2
5	GASKETS	# TFM	TFM	2
6	GASKETS	# Graphite	Graphite	2
7	BOLTS **	ASTM A193 B8	ASTM A193 B7	SET
8	STEM	17-4PH	17-4PH	1
9	O-Ring	# Viton	Viton	1
10	THRUST WASHER	# 50%SS PTFE	50%SS PTFE	1
11	STEM PACKING	# Graphite	Graphite	set
12	PACKING FOLLOWER	SS304	SS304	1
13	BELLEVILLE WASHERS	SS304	SS304	2
14	PACKING GLAND	SS304	SS304	1
15	GLAND BOLTS	SS304	SS304	2
16	STOP HOUSING	SS304	SS304	1
17	HOUSING BOLTS	SS304	SS304	4
18	TRAVEL STOPPER	SS304	Zinc Plated C.S.	1
19	SNAP RING	Nickel Plated C.S.	Nickel Plated C.S.	1
20	ANTI-STATIC SPRINGS	SS301	SS301	2
21	ANTI-STATIC BALLS	SS316	SS316	2
22	SPRING WASHERS	SS304	SS304	SET
23	HANDLE	DUCTILE IRON	DUCTILE IRON	1
24	SET SCREW	SS304	SS304	1

Parts included in the repair kits

* All SS welded ends 316L

** 316SS bolting available, C/F

Dimensions - Full Bore

Technical Submittal

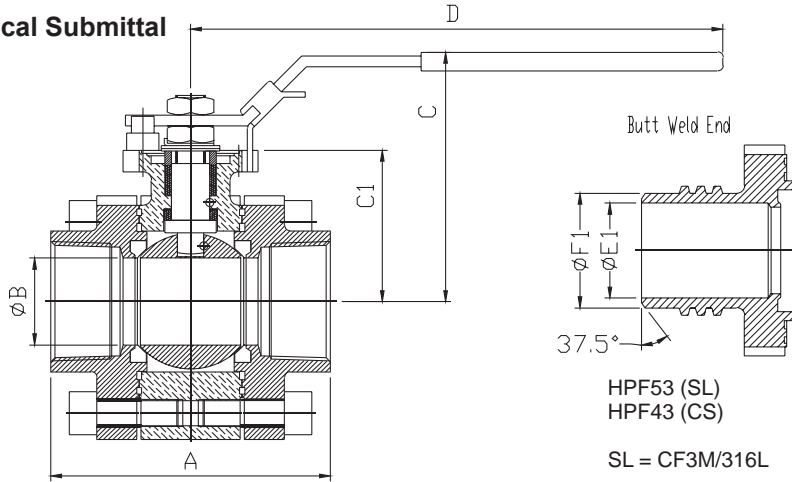

HPF53 (SL)
HPF43 (CS)

SL = CF3M/316L

Model HPF

Extra Long Butt Weld & Socket Weld Ends Are Also Available, Consult Factory.

Socket Weld End

Threaded End

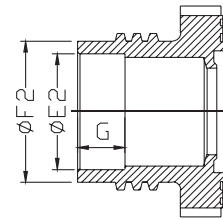

HPF52 (SL)
HPF42 (CS)

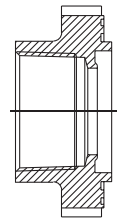

HPF51 (SS)
HPF41 (CS)

SIZE	A NPT	A BW, SW	B	C	C1	D	E1	E2	F1	F2	G	Cv	Torque	Weight Lbs SW
1/4"	2.72	4.81	0.46	2.80	1.54	6.57	0.46	0.56	0.71	1.02	0.39	18	75	2.5
3/8"	2.72	4.81	0.50	2.80	1.54	6.57	0.50	0.69	0.71	1.02	0.39	18	75	2.5
1/2"	2.91	4.89	0.59	2.80	1.54	6.57	0.59	0.85	0.85	1.24	0.39	18	85	3
3/4"	3.39	5.17	0.79	2.95	1.70	6.57	0.79	1.07	1.07	1.52	0.51	42	140	4
1"	3.70	5.24	0.98	3.62	2.06	7.95	0.98	1.33	1.34	1.69	0.51	72	190	5
1 1/4"	4.09	5.72	1.26	3.74	2.19	7.95	1.26	1.67	1.69	2.17	0.51	124	320	9
1 1/2"	4.61	6.19	1.57	4.45	2.65	9.88	1.57	1.91	1.91	2.44	0.51	210	430	12
2"	5.20	6.62	1.97	4.45	2.91	9.88	1.97	2.41	2.38	2.95	0.63	350	560	16
2 1/2"	7.28	8.78	2.56	6.22	3.39	15.5	2.32	2.91	2.87	3.62	0.98	650	950	32
3"	8.74	10.00	2.99	7.13	4.45	15.5	2.99	3.52	3.50	4.29	0.98	950	1200	45
4"	13.50	17.00	3.94	9.41	5.53	22.5	3.82	4.54	4.50	5.31	1.18	1620	2150	62

APPLICABLE STANDARDS	
Body Wall Thickness	ASME B16.34 / 600 & 800
Basic Dimensions	ASME B16.34
Testing Standards	ASME B16.34, API598
NACE	MR-01-75

All valves 100% air tested under water at 80-100 psi. Complies with API-598, BS 6755 Pt. 2.

ATTENTION

MAWP/WOG is a do not exceed pressure at normal ambient NPT & Weld End Models

Mounting Dimensions

SIZE	d	K	L	M	P	W	ISO
1/4"	1.65	0.28	0.53	0.25	0.47	#10-24UNC	F04
3/8"	1.65	0.28	0.53	0.25	0.47	#10-24UNC	F04
1/2"	1.65	0.28	0.53	0.25	0.47	#10-24UNC	F04
3/4"	1.65	0.28	0.53	0.25	0.47	#10-24UNC	F04
1"	1.97	0.44	0.74	0.315	0.55	1/4-20UNC	F05
1 1/4"	1.97	0.44	0.74	0.315	0.55	1/4-20UNC	F05
1 1/2"	2.76	0.53	0.88	0.374	0.63	5/16-18UNC	F07
2"	2.76	0.53	0.88	0.374	0.63	5/16-18UNC	F07
2 1/2"	CONSULT FACTORY						
3"	4.02	1.75	2.76	0.669	1.10	1/2-13UNC	F10
4"	4.92	2.03	2.91	1.024	1.34	1/2-13UNC	F12

IMPORTANT: Mounting Dimensions Are for Estimating Purposes Only. Consult Factory Before Manufacturing

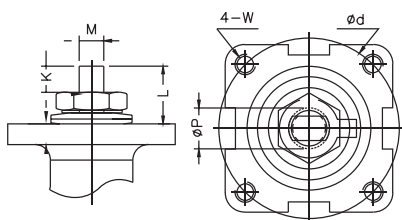

1/4" - 2" Size

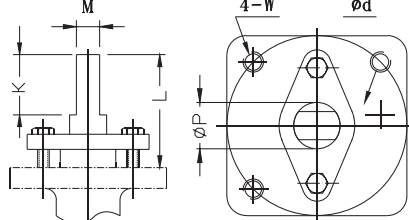

3" - 4" FP Size

Chart 1 Pressure Temperature Rating

If temperature exceeds 500 deg F, consult factory

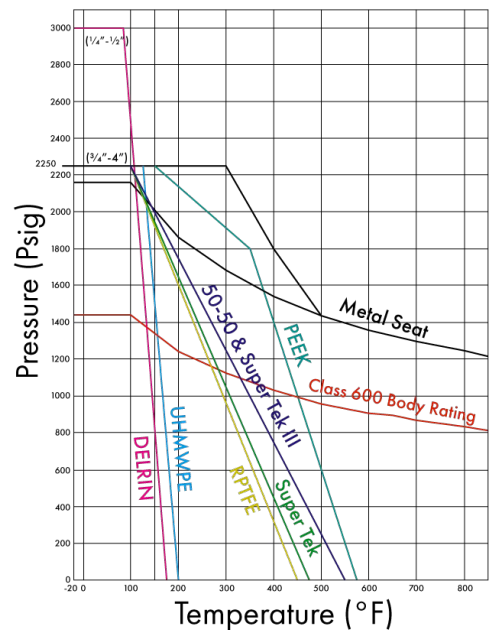

Body rating in the chart is for CF8M material. Max. WCB body rating is 1480 psi for class 600. Consult factory for Rating higher than 800°F

C/F for 2 1/2" FP & 3" RP

Disassembly is not Suggested. Disassembly will VOID the valve warranty.

Dimensions - Reduced Bore

Technical Submittal

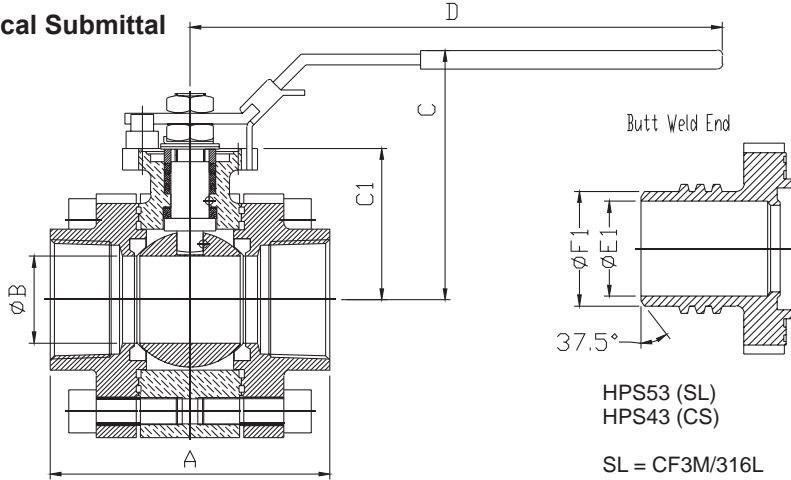

HPS53 (SL)
HPS43 (CS)
SL = CF3M/316L

Model HPS

Extra Long Butt Weld & Socket Weld Ends Are Also Available, Consult Factory.

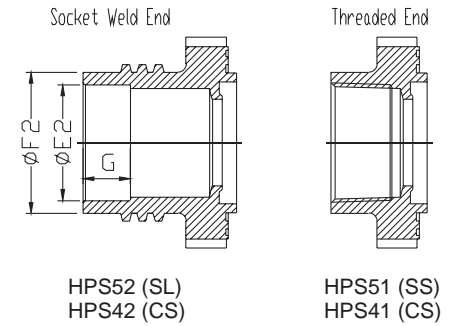

HPS52 (SL)
HPS42 (CS)

HPS51 (SS)
HPS41 (CS)

SIZE	A NPT	A BW, SW	B	C	C1	D	E1	E2	F1	F2	G	Cv	Torque	Weight Lbs SW
1/2"	2.87	4.85	0.50	2.80	1.54	6.57	0.55	0.85	0.84	1.14	0.39	18	75	3
3/4"	3.11	4.89	0.59	2.80	1.54	6.57	0.74	1.07	1.05	1.38	0.51	20	85	4
1"	3.62	5.17	0.79	2.95	1.70	6.57	0.96	1.33	1.31	1.69	0.51	40	140	5
1 1/2"	4.13	5.72	1.26	3.74	2.19	7.95	1.50	1.91	1.90	2.36	0.51	120	320	12
2"	4.76	6.19	1.57	4.45	2.65	9.88	1.94	2.41	2.37	2.83	0.63	200	430	16
2 1/2"	5.90	8.78	1.97	4.45	2.91	9.88	2.32	2.91	2.87	3.46	0.98	300	580	32
3"	9.06	9.57	2.56	6.22	3.39	15.5	2.90	3.54	3.50	4.18	0.98	640	985	55
4"	13.50	12.01	2.99	7.13	4.45	15.5	3.94	4.59	4.50	5.31	1.18	900	1250	85

APPLICABLE STANDARDS	
Body Wall Thickness	ASME B16.34 / 600 & 800
Basic Dimensions	ASME B16.34
Testing Standards	ASME B16.34, API598
NACE	MR-01-75

All valves 100% air tested under water at 80-100 psi. Complies with API-598, BS 6755 Pt. 2.

ATTENTION
MAWP/WOG is a do not exceed pressure at normal ambient NPT & Weld End Models

Mounting Dimensions

SIZE	d	K	L	M	P	W	ISO
1/2"	1.65	0.28	0.53	0.25	0.47	#10-24UNC	F04
3/4"	1.65	0.28	0.53	0.25	0.47	#10-24UNC	F04
1"	1.65	0.28	0.53	0.25	0.47	#10-24UNC	F04
1 1/2"	1.97	0.44	0.74	0.315	0.55	1/4-20UNC	F05
2"	2.76	0.53	0.88	0.374	0.63	5/16-18UNC	F07
2 1/2"	2.76	0.53	0.88	0.374	0.63	5/16-18UNC	F07
3"	CONSULT FACTORY						
4"	4.02	1.75	2.76	0.669	1.10	1/2-13UNC	F10

IMPORTANT: Mounting Dimensions Are for Estimating Purposes Only. Consult Factory Before Manufacturing

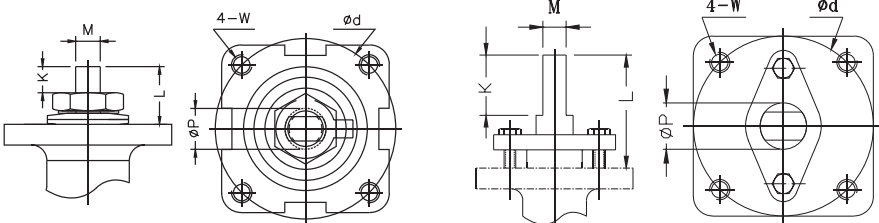

1/4" - 2 1/2" Size

C/F for 3" and 4" Size

Chart 2 Pressure Temperature Rating

If temperature exceeds 500 deg F, consult factory

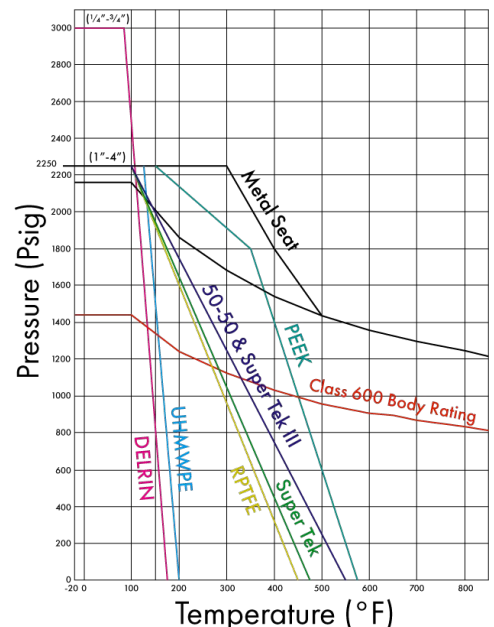

Body rating in the chart is for CF8M material. Max. WCB body rating is 1480 psi for class 600. Consult factory for Rating higher than 800°F

Dimensions - Flanged Class 600

Technical Submittal

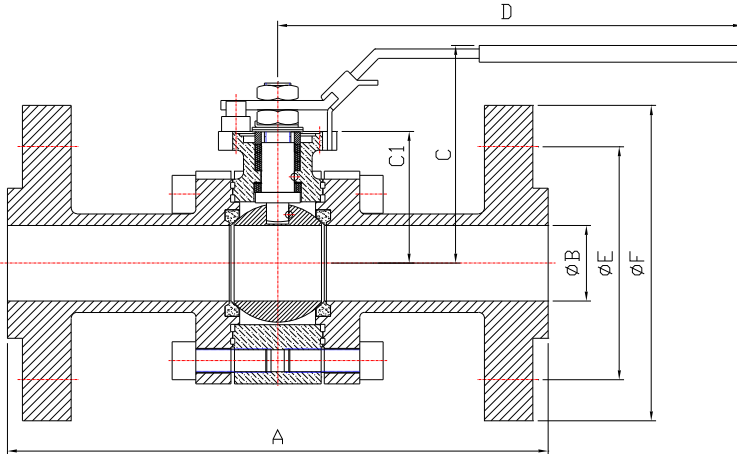

Pressure Temperature Rating

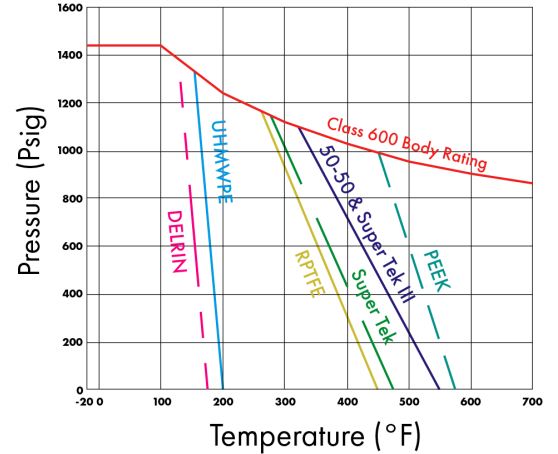

Body rating in this chart is for CF8M material. Max. WCB body rating is 1480 psi for class 600.

SIZE	A	B	C	C1	D	E	F	Cv	Torque in-lb
1/2"	6.50	0.59	2.80	1.54	6.57	2.62	3.75	18	90
3/4"	7.50	0.79	2.95	1.70	6.57	3.25	4.62	42	150
1"	8.50	0.98	3.62	2.06	7.95	3.50	4.88	72	200
1 1/4"	9.00	1.26	3.74	2.19	7.95	3.88	5.25	124	340
1 1/2"	9.50	1.57	4.45	2.65	9.88	4.50	6.12	210	450
2"	11.5	1.97	4.45	2.91	9.88	5.00	6.50	350	590
2 1/2"	13.0	2.56	6.22	3.39	15.5	5.88	7.50	650	1000
3"	14.0	2.99	7.13	4.45	15.5	6.62	8.25	950	1260
4"	17.0	3.94	9.41	5.53	22.5	8.50	10.75	1620	2260

APPLICABLE STANDARDS	
Body Wall Thickness	ASME B16.34/Class 600 & 800
NPT and SW Ends	ASME B16.11
Butt Weld Ends	ASME B16.25
Basic Dimensions	ASME B16.34
Testing Standards	ASME B16.34, API598
NACE	MR-01-75

All valves 100% air tested under water at 80-100 psi. Complies with API-598, BS 6755 Pt. 2.

Valves will be supplied with full cast or weld on flanges

Tri-Pro - Product Identification Code for Full Valve Model Numbers

MODEL	BODY MATERIAL		2ND END CONNECTION		VALVE - SOFT PARTS					OPERATOR		SIZE		
					SEAT	STEM SEAL	BODY SEAL							
SS - Full Port NPT HPF51 SW HPF52	316SS	SS	Threaded	1	TFM	F	Graphite	G	Graphite	G	Lever Locking	L	1/4	8
					CTFM	Y	TFM	F	TFM	F			3/8	10
BW HPF53 FLG HPF56	Alloy 20	A2	Butt Weld	3	PTFE	T	CTFM	Y	RTFM	X	Oval Locking	O	1/2	15
					RPTFE	R	PTFE	T	PTFE	T			3/4	20
CS - Full Port NPT HPF41 SW HPF42	316L	SL	Flanged 150	4	50/50	S	RPTFE	R	RPTFE	R	Gear	S	1	25
					UHMWPE	U	50/50	S	50/50	S			1 1/4	32
					PEEK	P	UHMWPE	U	UHMWPE	U			Actuator	G
SS - Reduced Port NPT HPS51 SW HPS52					Cavity Filled	C					Bare Stem	N	2	50
					Metal	M							2 1/2	65
													3	80
BW HPS53 CS - Reduced Port NPT HPS41 SW HPS42 BW HPS43													4	100

Ball: All ball material is supplied standard as 316SS & 304SS. If a different material is required, please specify as a special feature.

Stem: All stem material is supplied standard as 17-4PH. Please specify as a special feature if SS316 is needed.

Special Features are noted at the end of the identification number, please see special feature codes. For extended number, see Tech Bulletin page 188 in our catalog.

Ordering Examples by Part Numbers

MODEL	BODY MATERIAL	2ND END CONNECTION	SEAT	STEM SEAL	BODY SEAL	OPERATOR	SIZE	SPECIAL FEATURE
NPT END REDUCED PORT CS BODY	WCB	SW	TFM	Graphite	TFM	Lever	2"	Media Containment
HPS41	CS	- 2	- F	G	F	- L	- 50	- H3

Ordering Information

When placing an order or requesting a quotation, please provide as many details on the application as possible, such as media type, temperature, pressure, pipe size, and etc.

Dimensions - Actuation / Flow Data

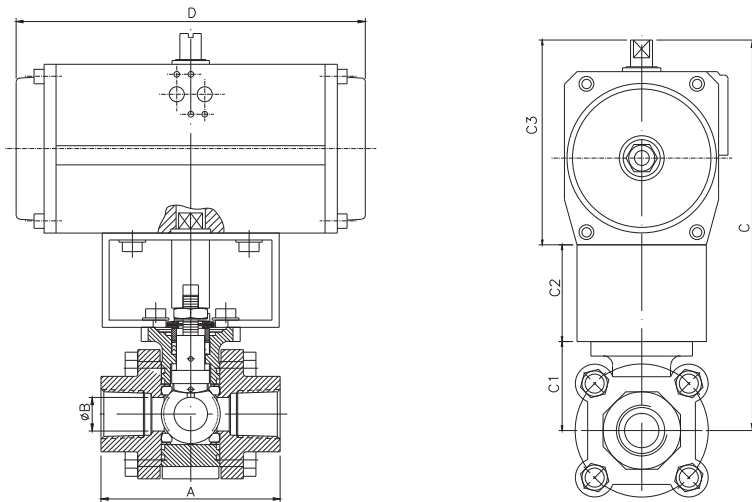

Pneumatic Actuator Dimensions shown in this drawing are for full port units based on 80 psi air to actuator, valves with standard seats, clean fluid only at ambient temperatures and pressures not to exceed 1500 psi. Consult factory for additional actuator types and dimensional drawings.

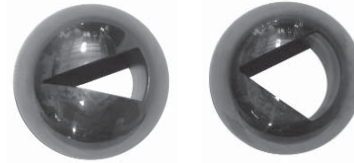

V-ports 15, 30, 60, 90 deg V & custom designs are available.

Tri-Pro in Control Valve Service

Flo-Tite also offers modulating V-port control valves. The V-ball is characterized to meet virtually all flow requirements. See tech bulletin 120-14.

SIZE	A 600# Flange	A NPT	A BW, SW	B	C1	C2	Spring Return Actuator 80psi				Double Acting Actuator 80psi			
							C3	C	D	Actuator Model	C3	C	D	Actuator Model
1/4"	-	2.72	4.81	0.46	1.54	1.57	4.23	7.34	6.61	SR063.9	3.15	6.26	4.81	DA040
3/8"	-	2.72	4.81	0.50	1.54	1.57	4.23	7.34	6.61	SR063.9	3.15	6.26	4.81	DA040
1/2"	6.50	2.91	4.89	0.59	1.54	1.57	4.23	7.34	6.61	SR063.9	3.15	6.26	4.81	DA040
3/4"	7.50	3.38	5.17	0.79	1.70	1.57	4.23	7.50	6.61	SR063.12	3.62	6.89	5.79	DA052
1"	8.50	3.70	5.24	0.98	2.06	1.57	4.23	7.86	6.61	SR063.9	4.23	7.86	6.61	DA063
1 1/4"	9.00	4.09	5.72	1.26	2.19	1.57	5.07	8.83	8.03	SR083.12	4.70	8.46	7.24	DA075
1 1/2"	9.50	4.61	6.19	1.58	2.65	1.88	5.39	9.92	10.4	SR092.12	5.07	9.60	8.03	DA083
2"	11.5	5.20	6.62	1.97	2.91	1.88	6.02	10.8	10.6	SR105.12	6.02	10.8	10.6	DA105
2 1/2"	13.0	7.28	8.78	2.56	3.39	4.00	6.89	14.3	11.7	SR125.12	6.02	13.5	10.6	DA105
3"	14.0	8.70	10.04	2.99	4.45	4.00	7.54	16.0	15.4	SR140.8	6.89	15.4	11.7	DA125
4"	17.0	9.84	13.00	3.94	5.53	4.00	8.54	20.1	18.1	SR160.9	7.54	19.1	15.4	DA140

All actuators above are generally sized for clean wet service

Torque Factors for Special Applications:

- 1 - Increase the breakaway torque by 20% for dry gas service or demineralized water.
- 2 - Add 10% for infrequent cycling.
- 3 - Add 40% for slurry or light abrasive content.
- 4 - Add 60% for metal seated valves, class V shut-off.
- 5 - Deduct 10% for high lubricity service.

Torque figures are for valves up to 1500 psi service. For higher pressure applications consult factory. Valve torque can vary due to pressure, media and temperature.

The information provided above should be considered as a guide only and must be adjusted according to experience and judgment.

All Tri-Pro Valves have integrally cast mounting pad, for ease of mounting actuation equipment.

Tri-Pro in Cryogenic Service



The Tri-Pro series can be provided specifically for cryogenic applications. All cryogenic ball valves have extended bonnets. They offer exceptional performance under the most extreme cold working temperature conditions. See tech bulletin page 138.



3-Way Diverter
Sizes 1/4" - 2 1/2" available

True High Performance Ball Valve Technology

A superior quality, rugged, and universal purpose valve for all fluids. This valve is ideal for saturated or superheated steam, slurries, semi-solids, and corrosive services in endless industrial, chemical, power, gas, paper, and original equipment applications.

Three Piece Design	Offers a wide selection of pipe end connections. Swing out center body allows easy access to internal valve components.
Fully Protected Body Seals	Prevents seal ruptures in high pressure or steam applications.
Live-Loaded Blow-Out Proof Bottom Entry System	Self adjusts with pressure and temperature fluctuations. Blow-out proof bottom entry stem, antistatic grounds help prevent accidents and injuries.
Secure Body Bolting	Cap screws - fully encapsulated secure end caps to tapped center body. Insuring ease of foolproof body assembly every time. Also protects bolts from outside environment.
Integral Actuator Mounting Pad	Ideal for actuation, ISO-5211 bolting, actuators may be retrofitted without disturbing the pipeline. Allows for secondary containment unit to be added when necessary.
Captured Seats	Pocketed and recessed seats with secondary metal backup seal, meeting API607-7. Super-TEK TFM, S-TEK 50/50, metal seats and more.
Weld-in-Place	Heat sink construction allows in place welding, prevents damage to soft seat rings and eliminates the need to disassemble valve for welding. Assures safe & cost effective installation.
High-Strength Stem	Parallel flat stem head for positive ball position indication. High strength 17-4 PH stainless steel is provided as standard.
Lockable-Safety Handle	Prevents valves from being opened or closed accidentally. Lock-out meets OSHA standards with locking device.

MATERIAL IDENTIFICATION

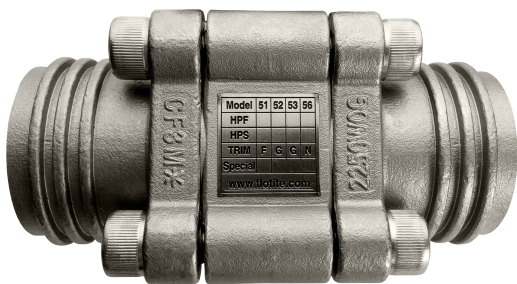

Flo-Tite's marking system follows MSS SP-25-1998 guidelines. In addition to the casted body information, all valves have metal nameplates that identify all valve soft parts. Valve users worldwide will be able to contact Flo-Tite quickly for any installation or service requirements as the company website address will be on all valves.

Tri-Pro with Media Containment Units



The ISO Mount platform is ideal for the addition of our secondary containment units.

Flo-Tite's media containment unit offers in-line maintenance for stem repair, protection for high temperature service, fugitive emission monitoring for early leak detection, and positive displacement. It also can be used as a high tech stem extension.



Flo-Tite, Inc.
4815 West 5th St.
Lumberton, NC 28358

P. O. Box 1293
Lumberton, NC 28359
Website: www.flotite.com

Tel: (910) 738-8904
Fax: (910) 738-9112
E-mail: flotite@flotite.com

Due to continuous development & improvement of our product range, we reserve the right to alter the dimensions and technical data included in this brochure.