

# spirax sarco

## Sealed Balanced Pressure Thermostatic Steam Trap DTS300

The welded stainless steel element is self-adjusting over the entire operating pressure range and will discharge condensate at approximately 190°F. Trap may be installed in horizontal or vertical pipelines.

<b>Model</b> □	<b>DTS300</b>
<b>PMO</b>	300 psig
<b>Sizes</b>	3/8" & 1/2"
<b>Connections</b>	NPT
<b>Construction</b>	All Stainless Steel Tamper-proof body
<b>Options</b>	Strainer Screen (For 1/2" size only)

### Limiting Operating Conditions

**Max. Operating Pressure (PMO)** 300 psig (21 barg)

**Max. Operating Temperature** Saturated Steam Temperature

### Pressure Shell Design Conditions

ANSI 600

**PMA** 800 psig/up to 725°F 55 barg/up to 385°C  
Max. allowable pressure

**TMA** 725°F/0-800 psig 385°C/0-55 barg  
Max. allowable temperature

### Typical Applications

Non-critical steam tracing systems.

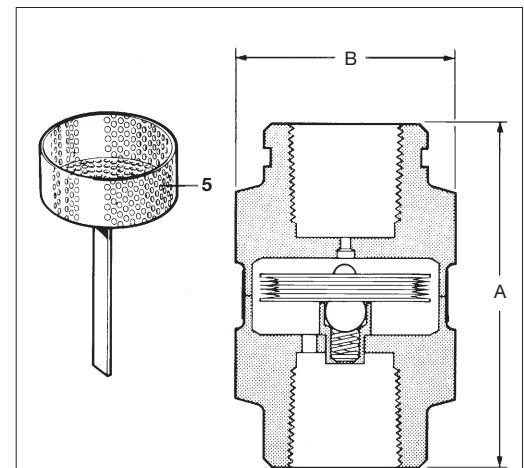
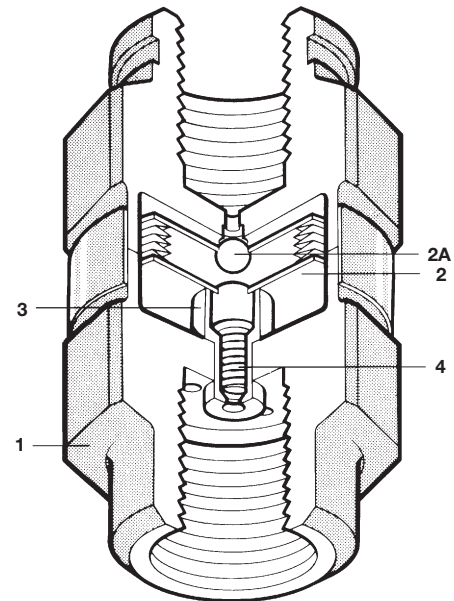

### Dimensions (nominal) in inches and millimeters

Size	A	B	Weight
3/8", 1/2"	2.5 64	1.5 38	0.7 lb 0.3 kg

### Construction Materials

No.	Part	Material
1	Body*	Stainless Steel AISI 304
2	Element Plates	Stainless Steel
2A	Element Valve	Stainless Steel
3	Element Holder	Stainless Steel
4	Spring	Stainless Steel
5	Strainer Screen (optional)** Screen Tab	Stainless Steel

\* The body weld joint complies with ASME section IX and BS4870 (1981).

\*\* Optional strainer screen can be inserted into the inlet connection.

# Sealed Balanced Pressure Thermostatic Steam Trap DTS300

## Capacities

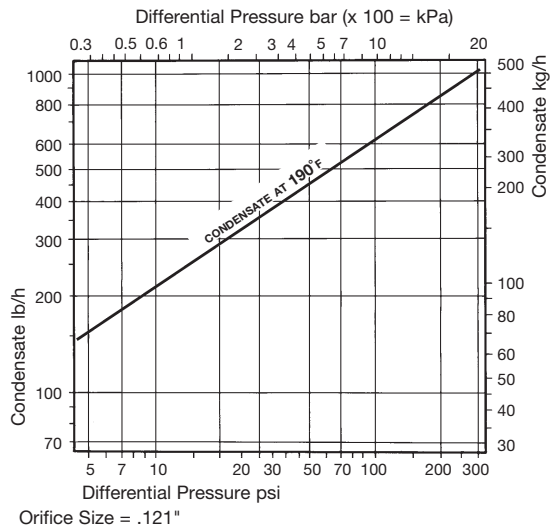

## Sample Specification

Steam trap shall be encapsulated Spirax Sarco DTS300 balanced pressure thermostatic type, which will operate installed in either horizontal or vertical piping. Construction of all stainless steel with tamper-proof body sealed against leakage. Operating element to be stainless steel welded thermostatic bellows for operation without adjustment at any pressure to 300 psig. Trap to operate close to 190 °F steam temperature and shall be provided with internal strainer when required.

## Operation

The DTS300 should be used for non-critical applications (such as non-critical tracing lines) where it is important to keep the temperature of condensate discharge low. The normal failure mode will be in the open position unless the bellows is distorted by severe operating conditions.

## Installation

The trap nameplate indicates the flow direction. A strainer should be installed upstream of the trap (an optional internal strainer is available). Full port isolating valves should be installed upstream. To avoid damaging the thermostatic element, the pipe connections should never be welded to the trap. For freeze protection, all drain lines must be pitched toward the trap for gravity flow. The trap must discharge vertically downward and the discharge piping must be self-draining.

## Maintenance

This product is factory sealed for tamper-proof operation, and no repair parts are available. Complete isolation of the trap from both supply and return line is required before the trap is removed. Complete installation and maintenance instructions are given in IMI 2.0001A, which accompanies the product.

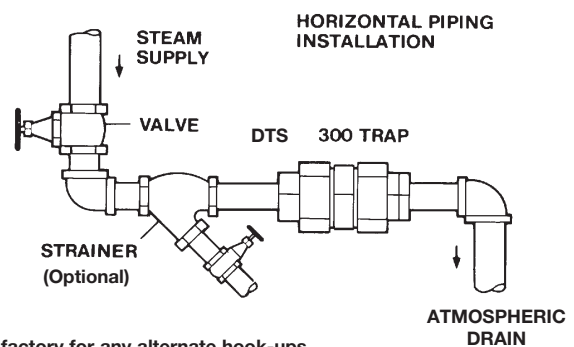
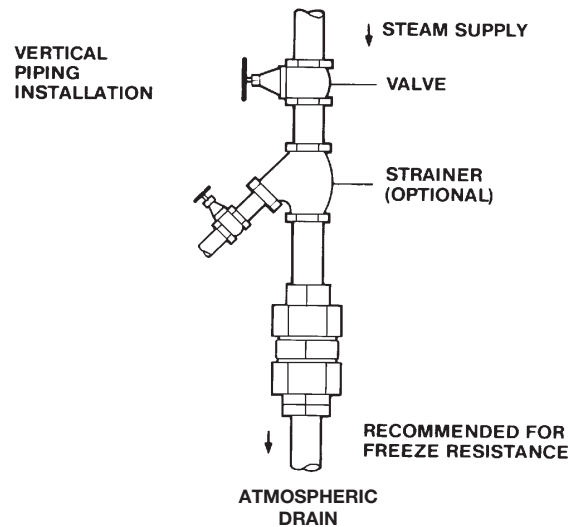
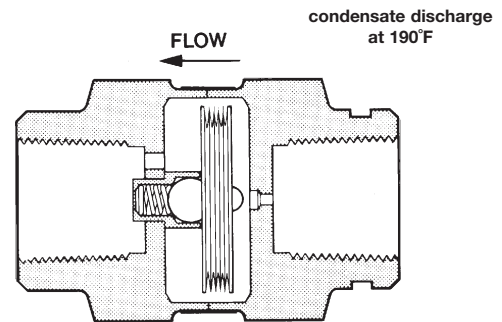

Consult factory for any alternate hook-ups.