



3 PC Direct Mount 110

Direct Connect Series

Models:

DM 110-SS

Pressure:

1000 WOG / 150 WSP

Size Range:

1/2"-3"

Temperature Range:

-20° F to 430° F

Material:

316SS - CF8M

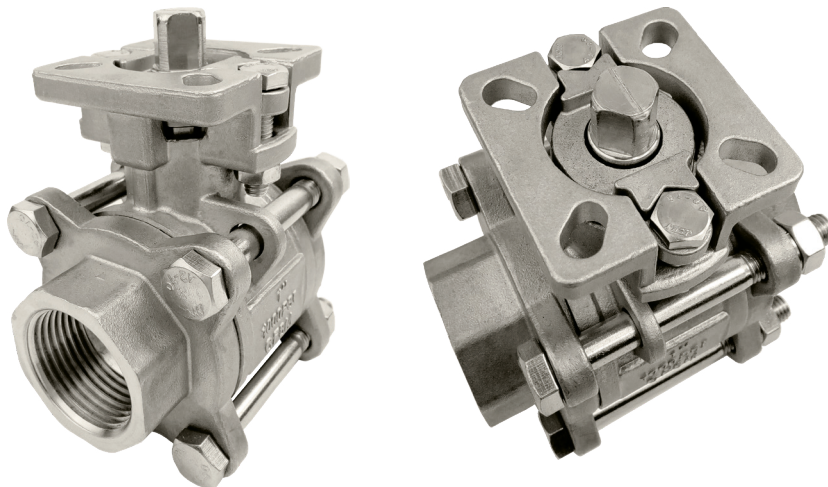

Easy Access Packing Gland

Bolted Packing Gland Design Provides Easy Adjustment of Stem Packing Even when "Direct Mounting" of Actuator is used.



Optional
30° & 60° VBall
Control Valve
50/50 Seats
Model: DMV-110

Stem Lead Detection Window Prevents Actuator Damage in the Event of Valve Stem Leakage.



Design Features:

- 3 Piece Body
- Full Port Design
- Threaded or Socket-Weld Ends
- Body: CF8M, 316SS
- Direct Mount - ISO 5211 - Provides precise shaft alignment & eliminates the need for brackets and couplings
- Three Piece Swing Out Design for easy maintenance
- Improved Seat Material - Extends cycle life and reduces torque
- Blowout-proof Stem
- Anti-Static Device - Standard in all sizes
- Adjustable "Live Loaded" Stem Seal
- Threaded NPT Ends per ASME B1.20.1

Direct Connect Series

STANDARD PRODUCT NUMBER
DM110-SS-1-RTT-N

Seat Options:

RPTFE (R)
PTFE (T)
S-TEK (50/50)

Lever Operator (Optional)



Economical Flow Control for Both Manual & Automation Designs
www.flotite.com

Design and Technical Data

Standards
ANSI/ASME - B16.11
ISO - 5211
MSS - SP25, SP72
ASME/ANSI B1.20.NPT

Dimensions and Weights

Size	d	L	W	H2	G	H1	H3	E1	U1	E2	U2	Cv	Torque	Weight
½"	0.59	2.95	7.24	2.01	0.35	0.31	3.39	1.97	0.28	1.65	0.24	20	89	2.29
¾"	0.79	3.15	7.24	2.05	0.35	0.31	3.43	1.97	0.28	1.65	0.24	38	89	2.38
1"	0.98	3.54	7.8	2.4	0.43	0.39	3.78	1.97	0.28	1.65	0.24	72	107	3.00
1¼"	1.26	4.33	7.8	2.83	0.43	0.51	4.21	1.97	0.28	1.65	0.24	93	133	6.33
1½"	1.5	4.72	9.13	3.27	0.55	0.67	4.84	2.76	0.35	1.97	0.28	145	222	7.87
2"	1.97	5.51	9.13	3.66	0.55	0.67	5.24	2.76	0.35	1.97	0.28	230	355	11.73
2½"	2.52	7.28	11.46	4.45	0.67	0.87	6.81	4.02	0.43	2.76	0.35	406	443	20.86
3"	3.15	8.07	11.46	4.69	0.67	0.87	7.05	4.02	0.43	2.76	0.35	576	620	33.21

Unit: inches
Size 2½" Consult Factory

Dimensions and Weights

Size	d	L	W	H2	G	H1	H3	E1	U1	E2	U2	Cv	Torque	Weight
½"	15	75	184	51	9	8	86	50	7	42	6	20	89	1.04
¾"	20	80	184	52	9	8	87	50	7	42	6	38	89	1.08
1"	25	90	198	61	11	10	96	50	7	42	6	72	107	1.36
1¼"	32	110	198	72	11	13	107	50	7	42	6	93	133	2.87
1½"	38	120	232	83	14	17	123	70	9	50	7	145	222	3.57
2"	50	140	232	93	14	17	133	70	9	50	7	230	355	5.32
2½"	64	185	291	113	17	22	173	102	11	70	9	406	443	9.46
3"	80	205	291	119	17	22	179	102	11	70	9	576	620	15.06

Unit: mm
Size 2½" Consult Factory

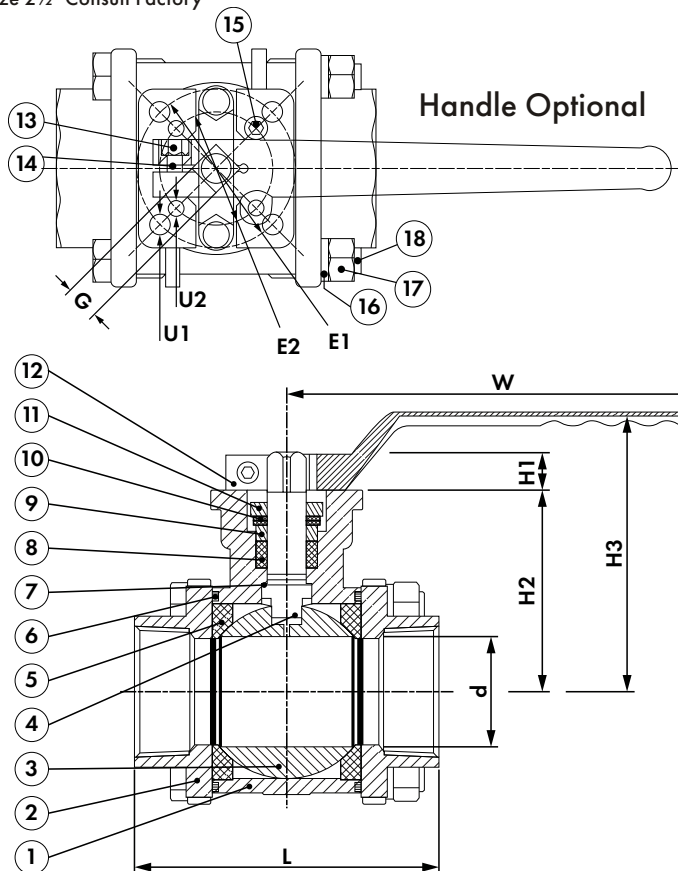

ISO 5211 Direct Mounting Pad Provides Precise Shaft Alignment and Eliminates the Need for Bracket and Coupler

Options:
V-Port
30°/60° Ball Design
Model DMV-110

Materials of Construction

No.	Part Name	Material	Qty
1	Body	CF8M	1
2	End Caps	CF8M	2
3	Ball	SS316	1
4	Stem	SS316	1
5	Seats	# PTFE/RPTFE	2
6	Gaskets	# PTFE	2
7	Stem Seal	PTFE	1
8	Packing	# PTFE	1
9	Gland	# SS304	1
10	Belleville Washers	# SS301	2
11	Gland Flange	CF8M	1
12	Handle	CF8	1
13	Handle Nut	SS304	1
14	Handle Bolt	SS304	1
15	Stop Pin	SS304	1
16	Bolt Washers	SS304	4
17	Bolt Nuts	SS304	4
18	Bolts	SS304	4

Optional Body Materials Available, Consult Factory
Repair Kits

ATTENTION
MAWP/WOG is a do not exceed pressure at normal ambient NPT & Weld End Models

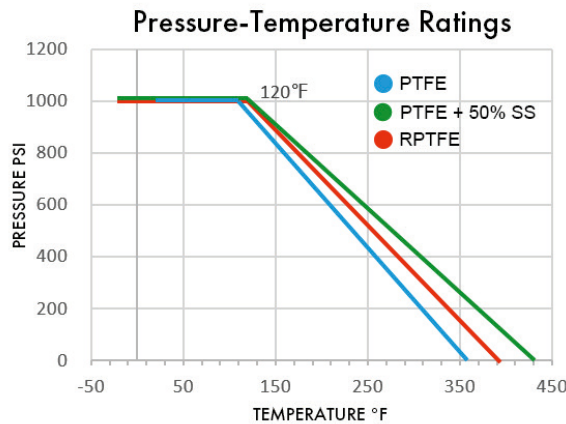

For steam applications Consult Factory



4815 West 5th Street www.flotite.com
Lumberton NC, 28358

Office: 910.738.8904
Fax: 910.738.9112
sales@flotite.com

Due to continuous development & improvement of our product range, we reserve the right to alter the dimensions and technical data included in this brochure